

# ATLANTA™



**Martina Tierney**

Occupational Therapist & Creator of the Atlanta

“Since becoming an Occupational Therapist 30 years ago, I’ve worked to improve the quality of people’s lives through seating, and every day I see their lives dramatically changed as a result. The results are amazing”



# THE ONLY CHAIRS SUPPORTED BY COMPREHENSIVE CLINICAL EVIDENCE

Download the full research summary here: **Seating Matters Ulster Research Summary**

The significant results\* have demonstrated what we already believe, that the correct use of clinical, therapeutic seating can lead to:

- ✓ Pressure injury reduction.
- ✓ Improved posture and function.
- ✓ Reduced sliding and falling from chairs.
- ✓ Reduced time spent in bed.
- ✓ Improved comfort and quality of life.
- ✓ Reduced expenditure on staff and resources.

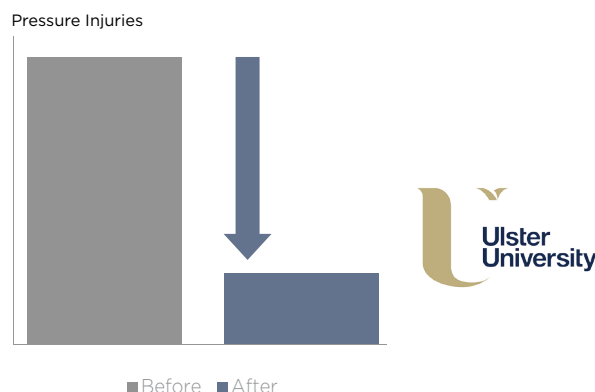

**\*Please review full details - <https://www.seatingmatters.com.au/clinical-benefits/>**

## THE FOUR PRINCIPLES OF PRESSURE MANAGEMENT IN SEATING

### 1. Load the Body

Ensure full body is in contact with the chair to redistribute pressure off bony prominences. Don't forget to load the feet! 19% of body weight goes through our feet.



### 2. Provide Postural Support

Posture and pressure are inextricably linked. Support any fixed or flexible deviations in posture with the correct seating and accessories to avoid uneven pressure redistribution.

### 3. Effective Repositioning

Guidelines recommend that seated individuals are repositioned every two hours to increase blood flow to skin. Functions such as tilt in space and back angle recline make this easier.



### 4. Appropriate Surface

All weight bearing parts of the chair should facilitate immersion, envelopment and support of the patient's body. The Seating Matters chairs are made up of Dartex covered pressure redistributing foam.



If you are looking for a safe, comfortable chair that provides dignity to people at risk of falling, sliding or injuring themselves, the Atlanta has been designed for that purpose.

The Atlanta can accommodate people who are challenging to seat, and is often used for those with Huntington's Disease, late stage dementia or in a palliative care setting. The chair is low to the ground and very stable. This reduces the risk of tipping due to vigorous involuntary movements or impulsive behaviours. The chair is well padded and has no areas of entrapment, reducing the risk to the user.

The integrated tilt and recline positions the person deep into the chair, helping to reduce sliding. The deep seat position provides a soothing and reassuring environment to promote calm and relaxation. The high arm rests help support those who tire and have difficulty maintaining an upright posture.

The angle adjustable leg rest can be adjusted to position the feet above the user's hips to help those with swelling in their legs.

### Suitable For These Conditions

- ✓ Huntington' disease.
- ✓ Alzheimer's disease.
- ✓ Parkinson's disease.
- ✓ Lower limb oedema.
- ✓ Advanced dementia.
- ✓ Cellulitis.
- ✓ Brain injury.

### MAIN USES

#### NDIS / Home Care - Care Facilities

Suitable for people at high risk of falling or sliding from chairs including those with rigorous movements and impulsive behaviours at risk of injury.

#### Hospital

Useful for those in high dependency wards at risk of pressure injury or falls, e.g. Transitional care unit, geriatric unit, palliative care and mental health.

# The Atlanta Chair Has:



Margaret Sitting In An Atlanta



BEFORE



AFTER

To learn more about Margaret's Story, visit the case study here:  
<https://www.seatingmatters.com.au/seating-range/atlanta/#case-studies>

# Atlanta Chair Features:



**Integrated Tilt and Recline** for pressure care, safety and comfort of the user.

**Dartex multi stretch pressure management materials** throughout all patient contact surfaces. This material is breathable with moisture permeability to ensure that the surface remains dry and comfortable for the user. This material can be wiped down for infection control and hygiene requirements.



**Medium to high pressure management cushion, using memory foam.** This cushion is removable for cleaning and if you wish to use a different type. An advantage of our memory foam cushions is they do not require maintenance or adjustment for each person, unlike a gel or air cushion. The cushion is also easily replaceable.

**Adjustable seat width, foot plate height and seat depth** allows the chair to fit the size and requirements of the user.

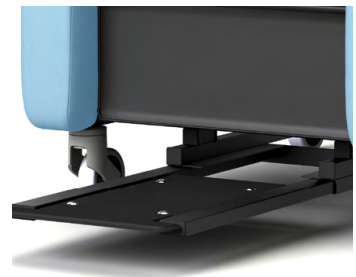

**Angle adjustable leg rest** for elevating the legs and managing swelling.

**A light weight frame with directional castors** to allow the chair to be easily pushed in a straight line or moved throughout a small room.

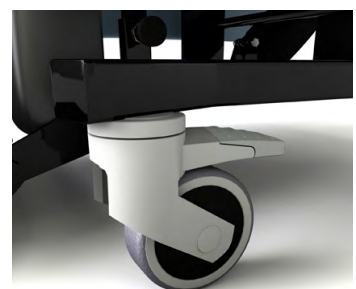

# Atlanta Parts & Accessories

Ramped Seat Cushion



Pressure Management Arms



Padded Arm Covers



Removable Seat Cover

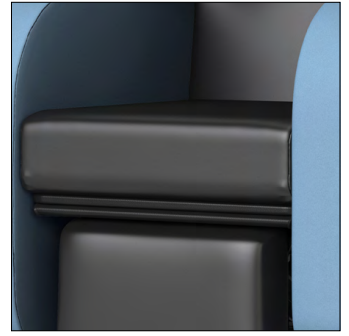

Tray Table



Removable Arm Covers



Sliding Footplate

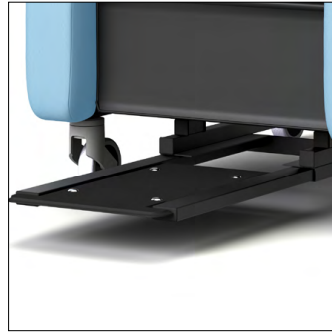

Padded Footplate

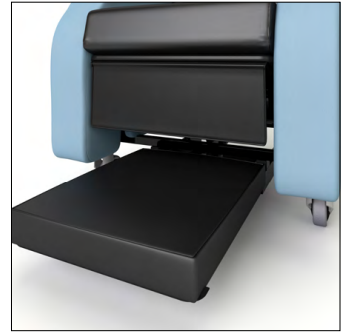

Horseshoe Pillow

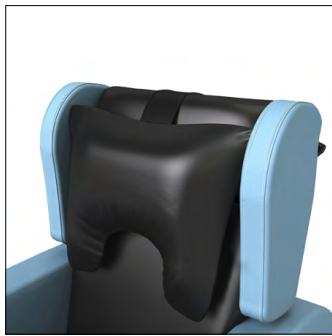

Head Pillow



Concave Pillow

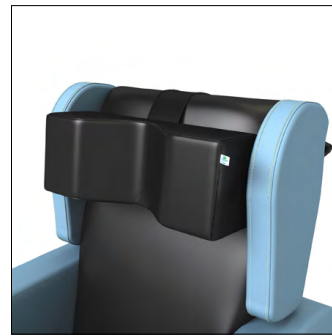

Seat Belt

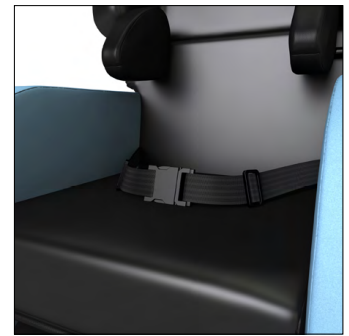

Padded Seat Belt Cover



4 Braked Castors On Chair

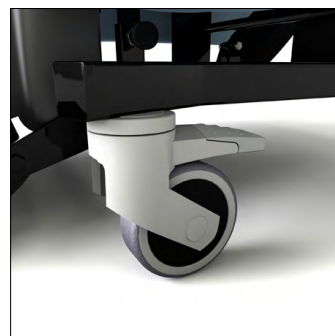

4 Braked Castors On Leg Rest



NexTier Cushion

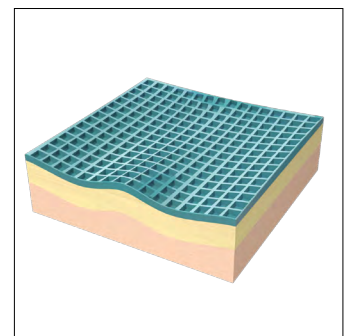

AirTier Cushion



Other Accessories - Atlanta

✓ Pelvic belts to provide support to the hips

# Atlanta Technical Specifications

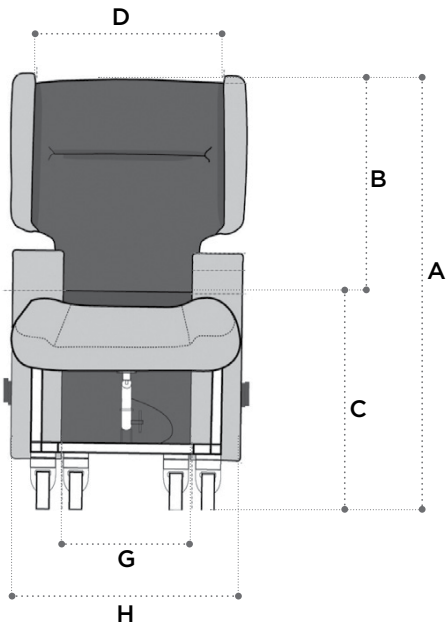

## Basic dimensions

<b>A</b>	Overall height	1135mm/45in
<b>B</b>	Back height	750mm/30in
<b>C</b>	Seat height	540mm/21in
<b>D</b>	Inside back width	505mm/20in
<b>E</b>	Overall length	1350mm/53in
<b>F</b>	Reclined length	1700mm/67in

## Available seat and overall widths

<b>G (Seat width)</b>	<b>H (Overall width)</b>
380mm/15in	635mm/25in*
450mm/18in	690mm/27in*
500mm/20in	690mm/27in*
550mm/22in	740mm/29in*
600mm/24in	790mm/31in*

\* Dimension includes legrest belt. Deduct 35mm/1.5in if belt is not used.

## Arm height options

<b>I</b>	Low	630mm/25in
<b>J</b>	High	660mm/26in

## Seat depth

<b>K</b>	480mm/19in
----------	------------

## Leg rest length

<b>L</b>	420mm/16.5in
----------	--------------

## Recline and tilt angles

### ii Back angle recline

110° - 140°

30° range

### iii Leg rest angle

75° - 107°

32° range

### iv Integrated tilt and recline

54° - 74°

20° range

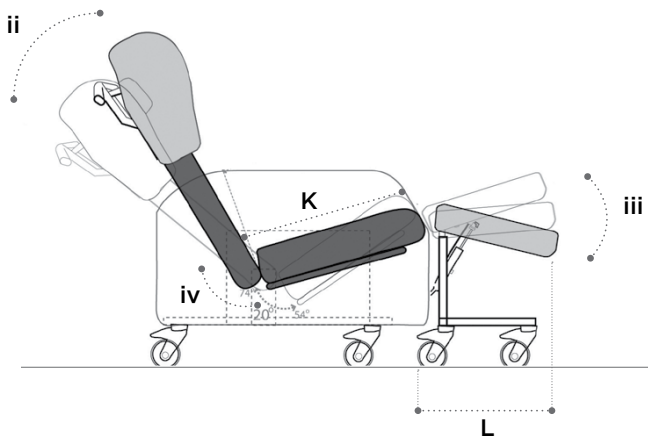
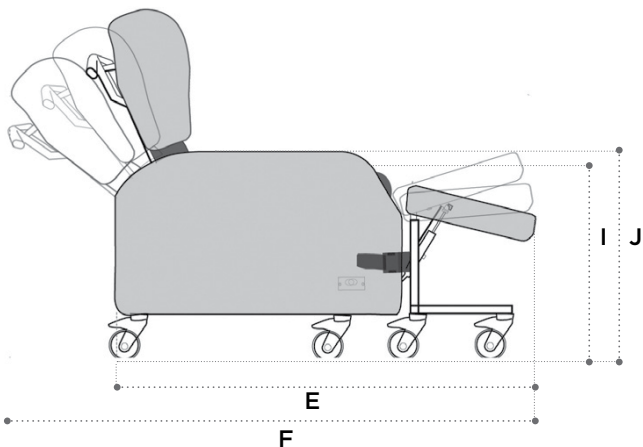

Chair weight unloaded is 67 Kg/147.71 lb/10.56 Stone.  
Chair user weight limit is 159 Kg/364 lb/25 Stone

# Infection Control

Infection prevention is vitally important in the home, hospital and healthcare environments. Bacteria and germs often contribute to the development and spread of infections. They can potentially be very harmful so this is important to control and prevent, especially in areas such as hospitals, where patients may be vulnerable and susceptible to infection.

Seating Matters take infection control very seriously. Our chairs have been specifically designed to decrease entrapment areas where bacteria and germs can survive.

**Dartex Multi-stretch (Patient contact surface). Waterproof, stain resistant, flame retardant, multidirectional stretch for pressure redistribution i.e seat cushion, calf panels, lateral supports and seat back.**

## BELOW ARE SOME OF THE STEPS WE HAVE TAKEN TO PREVENT THE SPREAD OF INFECTIONS:

- ✓ All chairs are upholstered in a hard-wearing, enduring contract vinyl proven to counteract C.difficile, E.coli as well as MRSA and the vast majority of bacteria.
- ✓ The materials can all be cleaned with hospital-grade cleaning agents, without causing damage to the fabrics. Please refer to the instructions on the specific cleaning solution you intend to use for best results.
- ✓ The seat cushion is removable for ease of cleaning.
- ✓ The seat cushion is attached to the base of the chair with a non-slip, wipeable material therefore having no materials such as Velcro which can hold dirt and bacteria.
- ✓ All electric components are part of a sealed unit which can be wiped clean.
- ✓ The metal frames of the chairs have a powder coated finish which is electro-statically applied then cured under heat to allow it to form a "skin". The powder is a thermoset polymer and is used to create a hard finish that is tougher than conventional paint, therefore protecting the frame from being exposed to outside conditions and thus preventing rusting.
- ✓ All chairs have modular parts which means the chair can be completely dismantled leaving no areas unexposed for cleaning.
- ✓ The complete chair frame is designed with flat panels throughout which can be easily wiped clean.
- ✓ Dartex Multi-stretch Fabric (Patient contact surface). Properties: This fabric is waterproof, has the ability to be wiped clean and has biostatic (anti-mycotic) coatings to provide an impenetrable barrier to virus and bacteria.





# Build Quality

It takes continuous, careful planning to ensure our chairs are functional as well as being aesthetically pleasing. Our design team are adamant that the chairs need to be designed in such a way that they fit into a home environment. Each and every part of a Seating Matters chair has been engineered and devised to offer optimum quality and support for the user.



## EASE OF USE

All Seating Matters chairs can be adjusted without tools in less than one minute. Useful to easily and efficiently adjust the chair to suit the user or to readjust for use within a multi-user environment.



## 7 YEAR WARRANTY

Have total peace of mind when relaxing in a Seating Matters chair as each one has passed some of the world's most stringent standards for strength, durability and safety. That's why we can uphold an industry leading 7 Year Frame warranty on the Atlanta chair with total confidence. Some terms and conditions apply, see our 7 Year Warranty booklet for full details.

**Seating Matters are an ISO 9001 Quality Management System approved company.**

**Seating Matters chairs are registered with the TGA - ARTG - 246892**



SEATING MATTERS CHAIRS ARE USED BY:



On NSW Health Contract  
HSSP\_HC19\_CF820



# Product Codes

CODE	ITEM
AT-500	ATLANTA, 500MM
AT-400	ATLANTA, 400MM, PRESSURE MANAGEMENT SPEC.

## Standard Fabric Options



Riviera Menton



Rosso Red



Ocean Blue



Cobalt Black



Grape Purple



Taurus Cream



Mocha

Other colour options are available for volume purchases.

\*Sorrento chair shown for illustration purposes.

# About-us

Hello, I'm Martina Tierney,  
I am an Occupational Therapist, Author, Educator and the Clinical Director of Seating Matters.

Throughout my 30 year career, I have worked in acute and community care, nursing homes and rehab, specializing in clinical seating provision. During my time working with patients, I discovered the profound effects poorly designed seating could have on patient outcomes and struggled to find chairs which met their clinical and functional needs.

After outlining the different features my patients required, including pressure care and easy adjustability, I set the goal to change the world of healthcare seating, by designing therapeutic chairs that would meet needs of bed-bound and low mobility patients.

## WHY SEATING MATTERS

It is sometimes hard for an able-bodied person to understand what it feels like to be sitting for long periods of time and how this affects your life sitting in a poorly designed chair. An able-bodied person can easily and unconsciously re-adjust their position before getting too uncomfortable.

As a comparison, think of the discomfort when you are sitting on a long-haul flight. You will get up and walk around to reduce any pain. This shows that a standard chair is not suitable for long term sitting.

Now imagine doing a long-haul flight every single day of your life.  
**That is what some people experience every day in their own homes, hospitals or care facilities and many haven't got the ability to change their own position!**

That is why getting the right chair for the right person is so important.

Even today, too many people continue to experience pain because of poor posture and poorly designed seating. Too many people are suffering a reduced quality of life from avoidable pressure injuries. Also far too much money is being spent by health services worldwide on reacting to these problems after it is too late.

**Clinical, functional seating can help solve these problems.**

As author of 'The Clinician's Seating Handbook' amongst other titles, I continue to research to find new solutions to seating challenges and help to educate audiences throughout the world on my findings.

Today, Seating Matters is changing the world through healthcare seating by improving the knowledge available to the healthcare community and by continually pushing the boundaries of seating innovations.



To download a copy of  
The Clinician's Seating  
Handbook, visit:  
[www.seatingmatters.com.au](http://www.seatingmatters.com.au)

**“Each day I realise more and more the impact of seating on people’s lives. For these people, the quality of their chair determines the quality of their life.”**

**— Martina Tierney, OT**

Seating Matters Australia  
9/256 New Line Road  
Dural NSW 2158 Australia

Phone: 1300 001 050  
Email: [info@seatingmatters.com.au](mailto:info@seatingmatters.com.au)



[www.seatingmatters.com.au](http://www.seatingmatters.com.au)